

MODEL 180 CONTROL PANEL

The automatic command center for the JET residential wastewater treatment system.

The Jet 180 - 194 pre-wired electrical control panels are designed to monitor the operation of the aerator, as well as up to one additional alarm circuit. Every control panel features an aerator warning light, circuit breaker, control switch, and terminal strip for easy wiring. These standard features provide cost-effective system operations when combined with several options for each site specific installation. The Jet Model 180 control panel is designed to control a single aerator circuit. The Jet Model 180 control panel is also equipped with an aerator timer, which is factory set to run the aerator 30 minutes every hour, the timer is adjustable for additional time settings. The Jet Model 180 Control panel has a single aerator warning light on the front of the panel.

INCLUDED FEATURES

1. **Enclosure** measures 4 X 3 X 8 inches with external reset button and stainless steel hasps.
2. **Aerator Warning Light** provides visual check of alarm condition.
3. **Circuit Breaker** for high operating temperatures.
4. **Control Switch** hand-off-automatic switch, for manual aerator control.
5. **Aerator Timer** factory set to run 30 minutes on and 30 minutes off, aerator run time can be increased if required



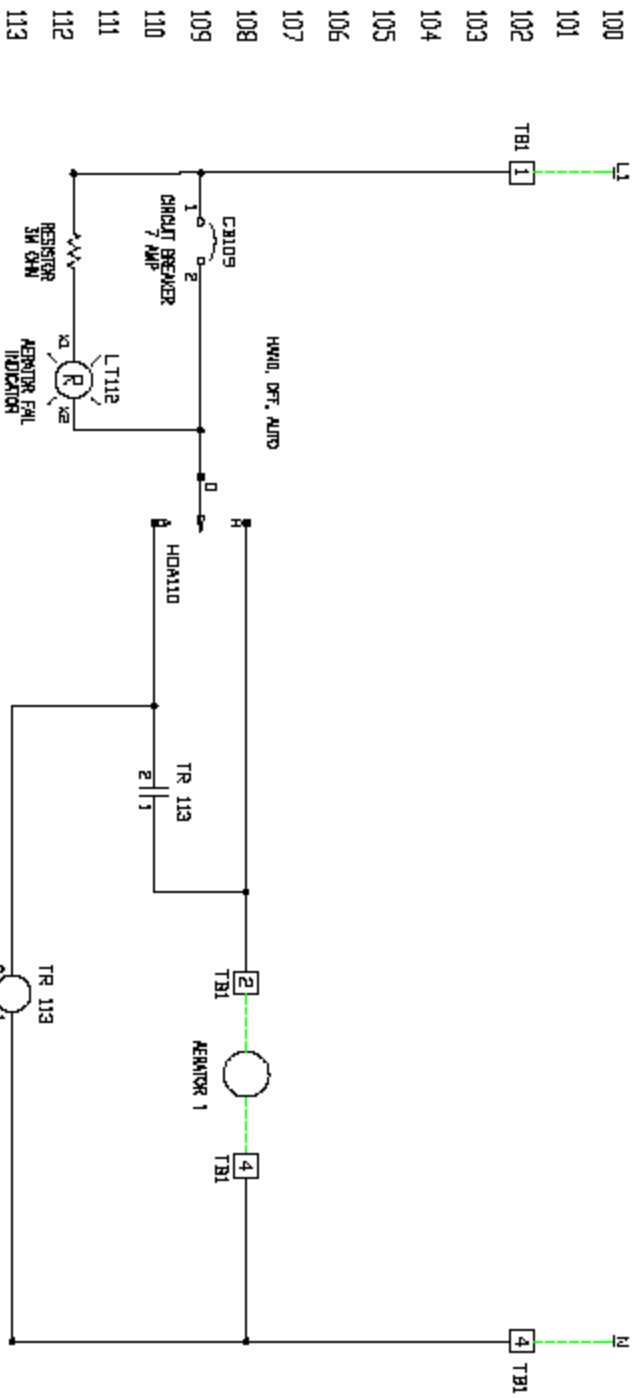

- 100
- 101
- 102
- 103
- 104
- 105
- 106
- 107
- 108
- 109
- 110
- 111
- 112
- 113

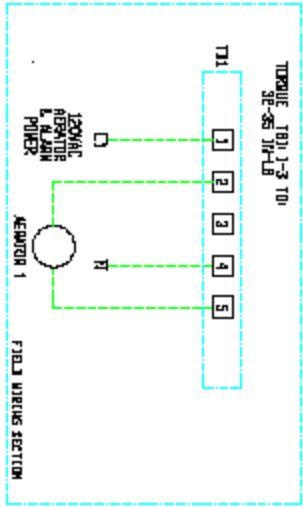

		TITLE: CONTROL PANEL, REECEL, U31 DATE: 11/13/09 DRAWN BY: JET INC. CHECKED BY: JET INC. APPROVED BY: JET INC.
PART NO.: 180 REV: 00 QTY: 1	DESCRIPTION: TORQUE TB1 1-3 TO JE-55 3P-ED	DATE: 11/13/09 DRAWN BY: JET INC. CHECKED BY: JET INC. APPROVED BY: JET INC.

